

Temperature Sensors for Aggressive Media



LIMATHERM SENSOR Sp. z o.o.
34-600 Limanowa, Skrudlak 1, tel. (+48 18) 330 10 06, fax: (+48 18) 330 10 04
NIP: 737 19 66 189, REGON: 492926443
www.limathermsensor.com, e-mail: export@limathermsensor.pl



Temperature Sensors for Aggressive Media

This Operation Manual provides information of temperature sensors with sheaths resistant to aggressive environments, suitable mainly for operating in chemical and galvanizing plants.

Sheaths of temperature sensors from this group have higher resistance to corrosive action of acids, alkalis or other materials:

- temperature sensor type TT...C-38: ceramic sheath on the basis of SiC,
- temperature sensors type TT...C-42: monocrystalline sheath on the basis of Al₂O₃,
- temperature sensors type TOPSZ..-157: sheath made of borosilicate glass
- temperature sensors type TOPCV..-1: stainless steel sheath, with additional PVC sheath
- temperature sensor type TOPE-142: sheath and handgrip are made of teflon.

Temperature sensors are manufactured in compliance with PN-EN 60584 and 60751 norms.

1. Construction and principle of operation.

The basic element of temperature sensors is thermocouple or resistance measuring insert:

- connected with terminals mounted on a ceramic disc and sheathed with a connection head made of aluminium alloy or thermoplastic
- extended with silicone or teflon insulated cable, derived from handgrip or directly from sensor sheath

The sensing element reacts to temperature change of process through the change of electromotive force (emf), in case of thermocouple sensors, or resistance change in case of RTD sensors. These changes are compatible with thermocouple characteristics specified for thermocouples in PN-EN 60584-1 and resistors in PN-EN 60751.

Measuring insert is placed in sheath with higher resistance to aggressive action of acids, alkalis and other media.

If necessary, the sensor can be equipped with transmitter of thermocouple or resistance signal to 4-20 mA or 0-10 V signals.

Specification:

Sensing element type.....	1 or 2x Fe-CuNi /J/, NiCr-Ni /K/, PtRh10-Pt/S/, PtRh13-Pt/R/, PtRh30-PtRh6/B/ acc. to PN-EN 60584 1 or 2 x Pt100, 500 or 1000 acc. to PN-EN 60751
Maximum temperature range.....	-50....500 °C for Pt 0....700 °C for J 0....1200 °C for K 600....1600 °C for R, S, B 600....1700 °C for B
Measuring junction type.....	insulated
Acceptable temperature of head operating.....	BA, BEG (-40→100) °C, NS (-30→80) °C
Degree of protection.....	IP55
Cable gland dimensions.....	M20x1,5

2. Resistance to environmental influence.

Sheaths used with these temperature sensors have higher resistance to aggressive media, some examples are given below:

Sheath type	Max. operating temperature of sheath in air	Examples of properties	Available dimensions OD/ID x L _{max}
SILIT SK ceramics	1350	Good resistance to hydrochloric, nitric, phosphoric and fluoric acids	ø25 /18 x 1500
SAPHIRE monocrystal	2000	Suitable for operating in liquid glass	ø5; 6x500-ø8 x 1000 - ø10 x 1400
SIMAX borosilicate glass	500	Very good resistance to most compounds	ø10 x 480; ø15 x 680
PVC heat-shrink jacket	100	Very good resistance to most inorganic compounds (except hydrochloric and nitric acids) low resistance to alcohols, oils and petrol	any
TEFLON drilled bar	250	Very good resistance to most compounds.	ø1 x 115

3. Installation.

Temperature sensors shall be mounted in compliance with the recommended way of installation, if possible, in places enabling control of operating and replacement in case of damage. The accuracy of measurement depends on the correct way of sensor installation. One shall remember that the temperature sensor transmits signals dependent on the temperature of the sensing element. Since the part of temperature sensor is beyond the place of measurement, in ambient temperature, and the sheath is a good thermal conductor, it results in change of temperature distribution in the place of measurement through constant heat removal. The bigger the ratio of length of this part of sensor which is in ambient temperature to the length of the whole sensor, and the bigger the difference between the ambient temperature and temperature in place of measurement, the bigger are the changes influencing the accuracy of measurement.

In the event of very accurate temperature measurements, the requirements given below shall be followed during the sensor installation:

- parts of temperature sensor beyond the place of measurement shall be thermally insulated
- connecting wires, especially in case of long distances, shall be arranged in a way preventing exposure to high temperature variations. In case of RTD sensor 3-wire connection is recommended
- longer (deeply immersed) sensors shall be used for obtaining a better ratio of sheath length in ambient temperature to total length
- pipelines with smaller cross-section shall be used in place of measurement for the purpose of increasing the flow velocity and intensification of heat transfer in pipelines with low flow rate (esp. gaseous).

- ceramic sheath shall not be exposed to temperature shock (temperature difference shall not be higher than 200K), if a higher resistance is not predicted.
- ceramic sheath shall be replaced in the event of damage or crack that exposes the thermocouple and brings the risk of direct contact with medium
- While in service one shall:
 - check the insulation resistance of connecting wires (minimum 3 MΩ)
 - check whether the terminals of a terminal block or transmitter are tight.
 - if the sensor works in the upper level of temperature range, the compatibility of sensor characteristic with the norm shall be checked at least once a year.

Minimum immersion length of RTD sensor – l_{min} .

- in flowing water $l_{min} = C + 5 D$
- in flowing air $l_{min} = C + 15 D$

C=30 mm - thermometer sensitive part;

D - outer diameter of the sheath.

4. Cable connection and arrangement.

Copper wire (for RTD sensors) or compensation cable (for TC sensors) with cross-section at least 1 mm² shall be used for connection between the temperature sensor and measuring device, in accordance with standards referring to low voltage installation. Wire connecting should be avoided.

If necessary, solder joints are recommended. During cable connection, one shall meet the requirements of the operation manual of the device intended to work with the temperature sensor.

For 3- and 4- wire RTD sensors, wires from one lead have the same insulation colour. Thermocouple sensors positive terminal must be joined device positive terminal and negative-to-negative. For making the installation easier, each country has standards specifying insulation and outer cover colour.

Diameter of the wire / Resistance of the wire

2x0,22 mm ² -0,175 Ω/m		2x0,25 mm ² -0,165 Ω/m
2x0,35 mm ² -0,105 Ω/m		2x0,50 mm ² -0,036 Ω/m

AI RTD sensors - designation of the connection terminals

- terminal block - one measuring circuit

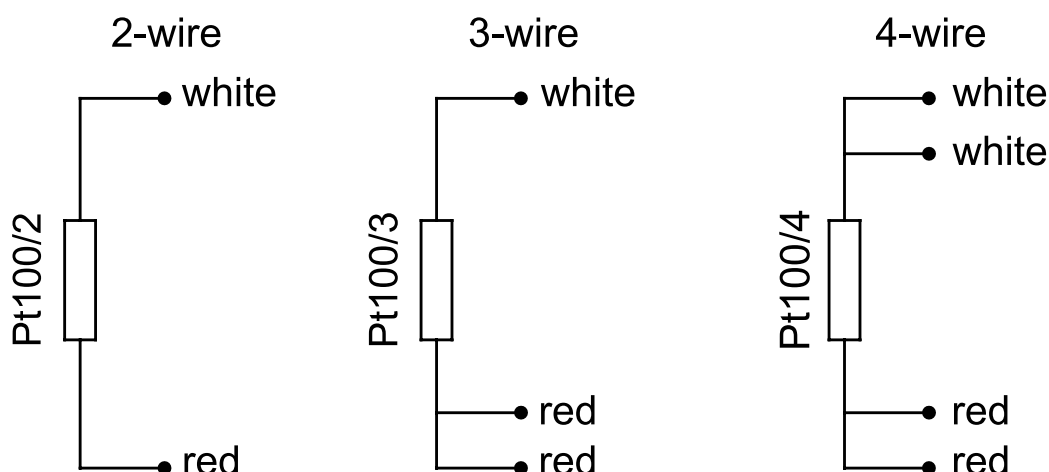

- terminal block - two measuring circuits

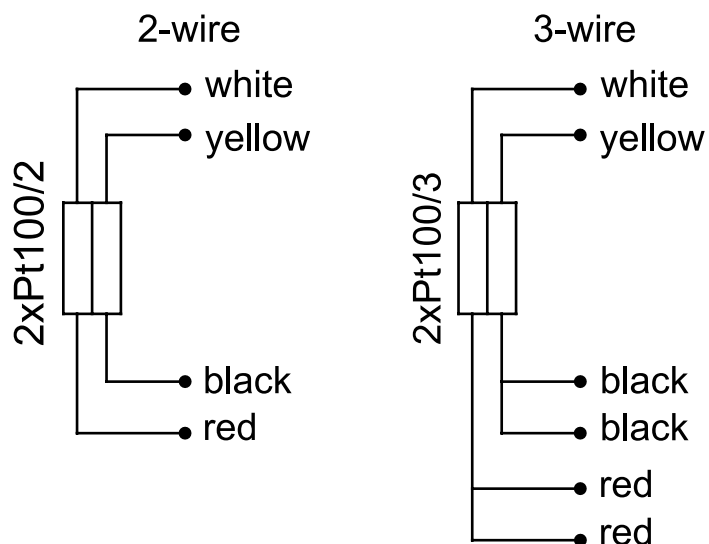

- transmitters RTD/4-20 mA or 0-10 V

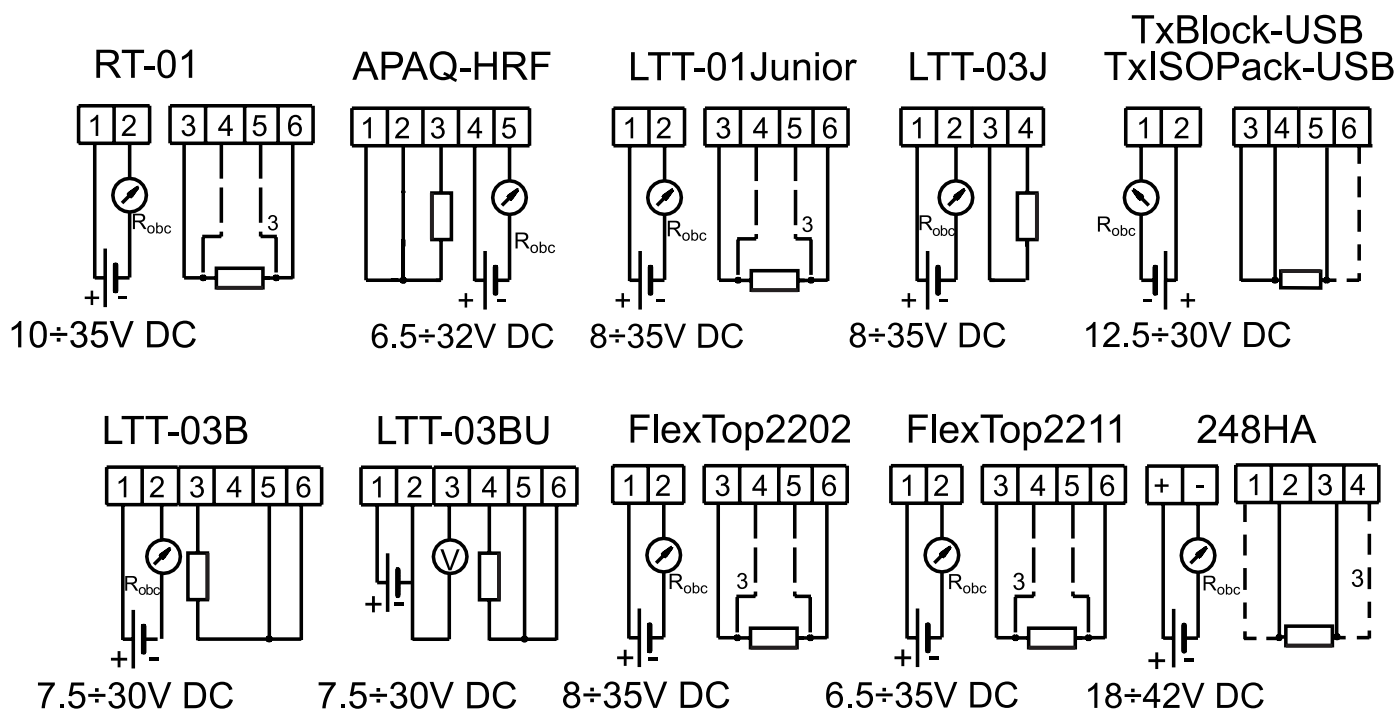

B/ Thermocouple sensors - designation of the connection terminals

Terminal block

Since thermocouple sensors must be connected with an adequate polarity, a sign “+” (thermocouple positive wire) is marked on a terminal block for the purpose of proper connection. In case of connecting the thermocouple sensor with outer devices an adequate pole of terminal block must be joined with an adequate pole of wire (proper colour). The terms of connection and colour codes are provided below:

Type of thermoelectric sensor	Type of wire		Metal Composition		Colour Code, „+”		Tolerances		Temperature range
	Compensation	Thermoelectric	Wire +	Wire -	IEC 584 „-”white	ANSI „-”red.	Class 1	Class 2	
J	-	JX	Fe	CuNi	black	white	±1.5	±2.5	-25÷200°C
K	-	KX	NiCr	NiAl	green	yellow	±1.5	±2.5	-25÷200°C
K	KCA	-	Fe	410 Alloy	green	-	-	±2.5	0÷150°C
K	KCB	-	Cu	CuNi	green	-	-	±2.5	0÷100°C
S/R	S/RC	-	Cu	CuNi	orange	white	-	±2.5	0÷100°C
B	BC	-	Cu	Cu	grey	pyrple	-	±5	0÷200°C

- Cross - sections of compensation and extension cables:
0,22 mm², 0,5 mm², 0,75 mm², 1,0 mm², 1,5 mm² 1,0 mm² or 1,5 mm² are recommended cross-sections of compensation and extension cables for connecting temperature sensors without devices acc. to PN-89/M-53859.

General rules for compensation cable designating (colour coding):

- acc. to PN-EN 60584: outer insulation and insulation of positive conductor (assigned to positive thermocouple element) is the same; negative conductor insulation - white
- acc. to PN-89/M-53859: cable outer insulation - different colours; insulation of positive conductor, assigned to positive thermocouple element - red; negative conductor insulation, assigned to negative thermocouple element - any colour except red, pink and purple
- transmitter TC/4÷20 mA

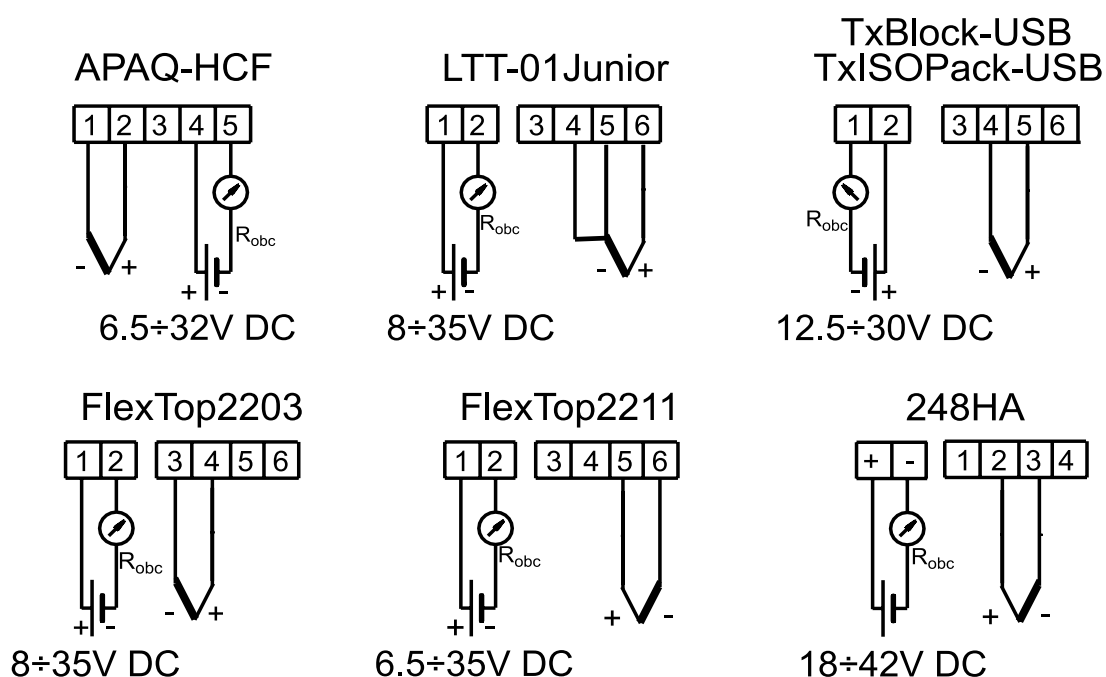

5. Recommended cable outer diameters for cable glands in connection heads of temperature sensors manufactured by Limatherm Sensor Sp. z o.o.

- for seal without notches – cable diameter / \varnothing 5,5 - 7,5 mm/
- for seal with notches – cable diameter / \varnothing 4 - 12,5 mm/

6. Packing, storing and transportation instructions.

For the purpose of transportation temperature sensors should be properly packed (in multipacks and/or as individual packages) in order to avoid any damage. They should be stored indoor in their original packages; the indoor air must be free of vapours and/or aggressive substances, the indoor air must range from +5°C to 50°C, and the relative humidity must not exceed 85%. Whilst being transported, the sensors must be protected against shifting inside the packaging.

Temperature sensors can be transported by air, by sea and road providing that the direct influence of atmospheric agents is eliminated. Transportation conditions acc. to PN-81/M-42009.

7. Warranty.

- The Manufacturer guarantees the proper service of temperature sensors for twelve (12) months, on condition that this period does not extend twenty four (24) months from the day of purchase.
- The warranty voids in the case of any changes and repairs of the instrument.
- This warranty does not cover damages resulting from improper transportation, nor defects caused by bad handling or misuse which does not comply with the provisions as set forth in this Operation Manual.
- Warranty period provided here does not cover the sensor sheaths.

8. Recommended examples of assembling the sensors.