

## Band heating elements **GM, GC**

### Technical description

#### Characteristic

- material: micanite or ceramic
- stainless steel sheath
- high efficiency
- long life

#### Application

Band heaters are used for heating:

- industrial pipes
- nozzles
- film blowing machines
- packing machines; injection moulding machine; extruders



Parameters	In micanite insulation	In ceramic insulation
Heater diameter [mm]	ø25+1000	ø50+1500
Width [mm]	25+1000	40+1000
Thickness [mm]	3,5+4	12+32
Supply voltage	24 V; 48 V; 220 V; 230 V; 380 V; 3x380 V; 400 V; 3x400 V; other	
Surface loading	4,5 W/cm <sup>2</sup>	7 W/cm <sup>2</sup>
Max. temperature	450 °C	550 °C
Allowable temperature	500 °C during good heat dissipation	600 °C during good heat dissipation
Housing	steel Cr-Ni (AISI 321), mosiądz	stal Cr-Ni (AISI 321)
Components additional	<ul style="list-style-type: none"> <li>– an adiabatic sheath holding heat radiation outside (of 25%)</li> <li>– possibility for applying thermocouple J, K, T</li> <li>– hermetic termination</li> <li>– type and way of power supply connections acc. to the figures or requirements</li> </ul>	<ul style="list-style-type: none"> <li>– an adiabatic sheath holding heat radiation outside (of 25%)</li> <li>– possibility for applying thermocouple J, K, T</li> <li>– type and way of power supply connections acc. to the figures or requirements</li> </ul>

Type A

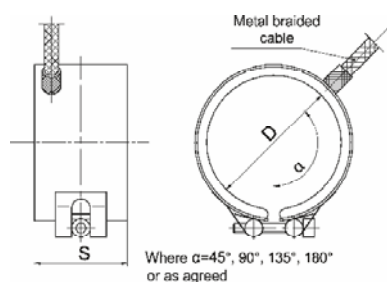

Type B

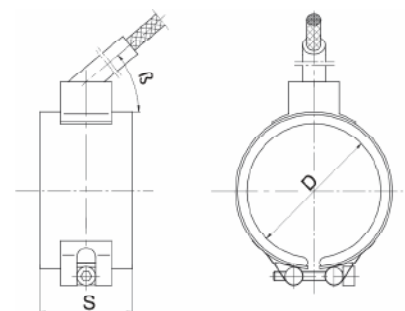

Type C

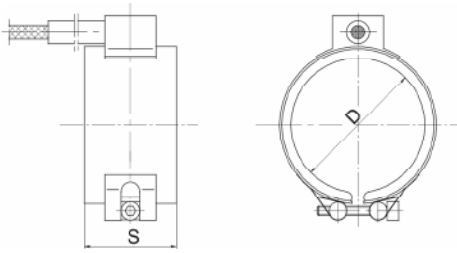

Type D

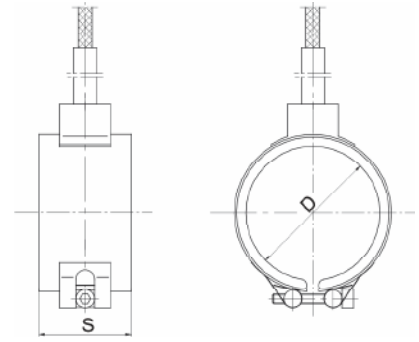

Type E

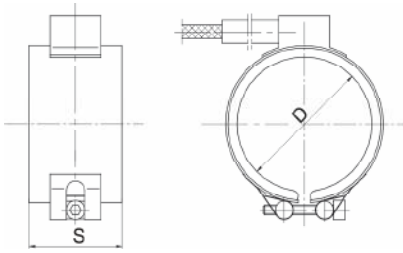

Type F

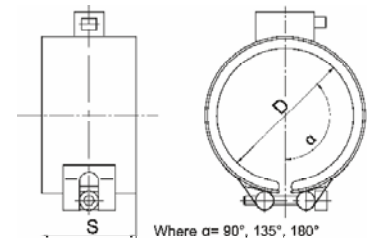

Type G

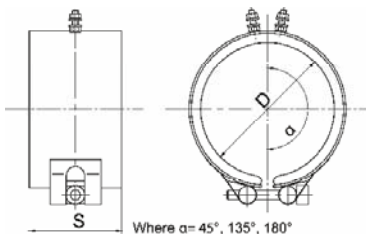

Type H

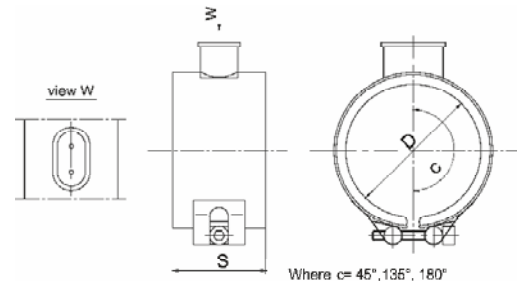

Ordering code

Band heating		... - - - - - / ... - - - - -	
Type:			
micanite	GM		
ceramics	GC		
Diameter* [mm]			
Width* [mm]			
Power* [W]			
Voltage* [V]			
Termination type:			
directly form the heater in overbraid			
axial (angle 3-70°)			A
axial fl at			B
radial			C
tangent flat			D
with block			E
screw: M5			F
plug			G
			H
Lead wire protection:			
none			0
adiabatic sheath			OS
Lead wire length [m]			

\* Acc. to requirements

Ordering example

Band heating GM-ø100-200-3000W/230V-A-0-1,5m

A